



Zanco

زانکو، هوای زندگی

HVAC PRODUCTION

PRODUCT CATALOGUE
EDITION 2024



تولیدکننده و صادرکننده سیستم‌های پیشرفته تهویه مطبوع

جهان
تاسیسات

محصولات زانکو با ضمانت جهان تاسیسات دیاکو پارس



www.zanco.co



Zanco

Chiller
Fan Coil
Duct Split

چیلر
فن کویل
داکت اسپلیت

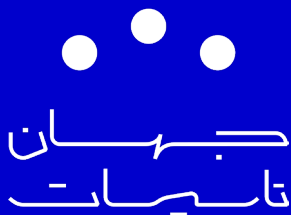

محصولات زانکو با ضمانت جهان تاسیسات دیاکو پارس

www.jtdpac.com

www.zanco.co

درباره زانکو

شرکت جهان تاسیسات دیاکو پارس از سال ۱۳۸۸ در زمینه مشاوره، طراحی، فروش و خدمات پس از فروش سیستم‌های پیشرفته تهویه مطبوع و با هدف ارائه خدماتی بالاتر از معیارهای استاندارد رایج در کشور فعالیت می‌کند.

مهم‌ترین هدف ما کسب رضایت کامل مشتری و فراهم آوردن آسایش و راحتی در منازل و محل کارشان می‌باشد.

ما توانسته‌ایم در زمان کوتاه نام خود و این برند با کمپرسورهای کولپند آمریکا ساخت تایلند و چین را در ایران پُرآوازه نماییم. در مرحله پس از فروش، پشتیبانی کامل در تمامی مراحل طراحی، اجرا، نصب و سرویس دورکاری در بازه‌های زمانی کوتاه‌مدت، از وظایف اصلی بخش فنی این شرکت می‌باشد.

انواع محصولات با کیفیت سرمایشی و گرمایشی مانند انواع چیلرها و مینی‌چیلرها، فن‌کوئل‌ها و داکت اسپلیت‌ها (اسپلیت یونیت کانالی) بخشی از طیف گسترده محصول ما می‌باشند.

معتقدیم خدمات و مشاوره صادقانه فنی و تخصصی در خصوص سیستم‌های تهویه مطبوع، ما را از دیگر همکاران فعال در این بخش متمایز می‌نماید. خدمات مشاوره فنی و مهندسی ما در دو مرحله قبل و بعد از فروش تجهیزات به شما ارائه می‌گردد. در مرحله قبل از فروش، مهندسان فروش و فنی ما با مشاوره و راهنمایی، شما را در خصوص تصمیم‌گیری و انتخاب بهترین نوع سیستم‌های تهویه مطبوع راهنمایی می‌کنند. ارائه پیشنهادهای فنی و مالی در قالب اسناد و نقشه‌های مهندسی از جمله خدمات رایگان شرکت جهان تاسیسات دیاکو پارس می‌باشد.

کلیه محصولات ارائه شده برند زانکو دارای برگ ضمانت مورد تایید سازمان حمایت از حقوق مصرف‌کننده بوده و مشمول خدمات پس از فروش می‌باشند. این خدمات توسط نمایندگی‌های این شرکت در تهران و شهرستان‌ها ارائه می‌گردند.

طی چند سال گذشته مشتری‌مداری و وفاداری به تعهدات، پایه و اساس شرکت را تشکیل داده است. ما معتقدیم با افزایش انتظارات و خواسته‌های مصرف‌کنندگان باهوش امروزی در صنعت تهویه مطبوع، ما نیز همواره در حال ارتقاء سطح فنی محصولات و پرسنل خود می‌باشیم.



Zancö

Index

مینی چیلر Mini Chiller	05
چیلر Chiller	08
فن کوئل سقفی تو کار استاندارد (سایلنت) Standard Built-In Ceiling Fan Coil (Silent)	22
فن کوئل سقفی تو کار اسلیم Slim Built-In Ceiling Fan Coil	27
فن کوئل کانالی Ducted Fan Coil	32
داکت اسپلیت Duct Split	35

مینی چیلر Mini Chiller



Mini Chiller

MODEL : COMPACT
AIR COOLED CHILLER

- Capacity : 4- 7 TON (Nominal)
- Compressor : Scroll – Copeland Or Danfoss
- Condenser : Air Cooled
- Fan : Zilabeg
- Evaporator : Shell & Tube
- Expansion Valve : Thermostatic



MODEL : COMPACT		UNIT	CSC22004	CSC22005	CSC22006	CSC22007
CAPACITY	COOLING	KW	11.4	14.0	17.0	19.2
		TON	3.2	4.0	4.8	5.5
COMPRESSOR	TYPE	SCROLL	1 Circuit	1 Circuit	1 Circuit	1 Circuit
	QTY	-	1	1	1	1
	BRAND	-	Copeland	Copeland	Copeland	Copeland
	MODEL	ZR	ZR48	ZR61	ZR72	ZR81
	REFRIGERANT	TYPE	R22/R407C	R22/R407C	R22/R407C	R22/R407C
	MAX CURRENT	A	6.5	7.38	7.93	9.5
CONDENSER	COIL	TYPE	Fin-Tube	Fin-Tube	Fin-Tube	Fin-Tube
		QTY	1	1	1	1
	FAN	MODEL	50	50	63	63
		QTY	1	1	1	1
		RPM	900	1320	900	900
EVAPORATOR	TYPE	Shell-Tube	Shell-Tube	Shell-Tube	Shell-Tube	Shell-Tube
	WATER VOLUME	Lit	23	24.5	26	28
	FLOW RATE	Lit/min	45	46	48	50
UNIT DIMENSION	L	Cm	150	150	150	150
	W	Cm	95	95	95	95
	H	Cm	130	130	130	130
CONNECTION	INLET/OUTLET	In	1	1	1-1/4	1-1/4
ELECTRICAL DATA	VOLTAGE	V	220/380	380	380	380
	MAX POWER INPUT	KW	5	6	7	8
	MAX CURRENT	A	10	11	12	13

CAPACITY CORRECTION OF AIR COOLED CHILLER		Air Temperature Over Condenser Coil (T Ambient) F								
		95 (35C)			100 (38C)			105 (40C)		
		Power Input (KW)	Cooling Capacity (KW)	GPM	Power Input (KW)	Cooling Capacity (KW)	GPM	Power Input (KW)	Cooling Capacity (KW)	GPM
AIR COOLED CHILLER	CSC22004	3.0	11.3	7.7	3.2	11.0	7.5	3.4	10.8	7.4
	CSC22005	3.6	13.9	9.5	3.8	13.5	9.2	4.0	13.2	9.0
	CSC22006	4.3	17.0	11.6	4.6	16.5	11.3	4.8	16.1	11.0
	CSC22007	4.8	19.2	13.1	5.0	18.6	12.7	5.3	18.2	12.4

Mini Chiller

MODEL : PERMIUM
AIR COOLED CHILLER

- Capacity : 8- 14 Ton (Nominal)
- Compressor : Scroll – Copeland Or Danfoss
- Condenser : Air Cooled
- Fan : Zilabeg
- Evaporator : Shell & Tube
- Expansion Valve : Thermostatic



MODEL : Permium		UNIT	PSC22008	PSC22010	PSC22012	PSC22014				
CAPACITY	COOLING	KW	22.5	30.0	34.2	37.0				
		TON	6.4	8.5	9.7	10.5				
COMPRESSOR	TYPE	SCROLL	1,2 Circuit	1,2 Circuit	1,2 Circuit	1,2 Circuit				
	QTY	-	1,2	1,2	1,2	1,2				
	BRAND	-	Copeland	Copeland	Copeland	Copeland				
	MODEL	ZR	ZR94 2*ZR48	ZR125 2*ZR61	ZR144 2*ZR72	ZR160 2*ZR81				
	REFRIGERANT	TYPE	R22/R407C	R22/R407C	R22/R407C	R22/R407C				
	MAX CURRENT	A	11	12	15	17				
CONDENSER	COIL	TYPE	Fin Tube	Fin Tube	Fin Tube	Fin Tube				
		QTY	1,2	1,2	1,2	1,2				
	FAN	MODEL	50	63	63	63				
		QTY	2	2	2	2				
		RPM	900	900	900	900				
EVAPORATOR	TYPE	Shell-Tube	Shell- Tube	Shell- Tube	Shell- Tube	Shell- Tube				
	WATER VOLUME	Lit	27	35	45	55				
	FLOW RATE	Lit/min	72	90	110	135				
UNIT DIMENSION	L	Cm	230	230	230	230				
	W	Cm	95	95	95	95				
	H	Cm	130	130	130	130				
CONNECTION	INLET/OUTLET	In	1-1/4	1-1/2	1-1/2	1-1/2				
ELECTRICAL DATA	VOLTAGE	V	380	380	380	380				
	MAX POWER INPUT	KW	8	10	11	13				
	MAX CURRENT	A	15	17	20	23				
CAPACITY CORRECTION OF AIR COOLED CHILLER	Air Temperature Over Condenser Coil (T Ambient) F									
	95 (35C)			100 (38C)			105 (40C)			
	Power Input (KW)	Cooling Capacity (KW)	GPM	Power Input (KW)	Cooling Capacity (KW)	GPM	Power Input (KW)	Cooling Capacity (KW)	GPM	
	PSC22008	5.5	22.5	15	5.9	21.7	15	6.1	21.2	14
PSC22010	7.2	30.0	20	7.8	29.0	20	8.1	28.4	19	
PSC22012	8.2	34.2	23	8.8	33.1	23	9.1	32.3	22	
PSC22014	9.2	37.0	25	9.8	35.8	24	10.2	34.9	24	

چیلر Chiller



Chiller

MODEL : MIDDLE- SCROLL- R22
AIR COOLED CHILLER

- Capacity : 15- 30 Ton (Nominal)
- Compressor : Scroll- Copeland Or Danfoss
- Condenser : Air Cooled
- Fan : Zilabeg
- Evaporator : Shell & Tube
- Expansion Valve : Thermostatic

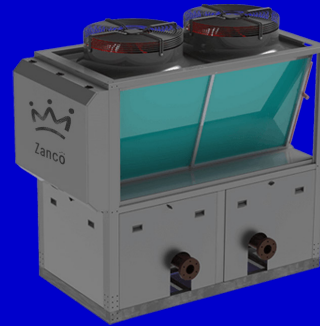

MODEL : Middle- Scroll- R22		UNIT	MSC22015	MSC22020	MSC22025	MSC22030
CAPACITY	COOLING	KW	45.0	60.0	68.4	87.8
		TON	12.8	17.1	19.4	25.0
COMPRESSOR	TYPE	SCROLL	2 Circuit	2 Circuit	2 Circuit	2 Circuit
	QTY	-	2	2	2	2
	BRAND	-	Copeland	Copeland	Copeland	Copeland
	MODEL	ZR	ZR94	ZR125	ZR144	ZR190
	REFRIGERANT	TYPE	R22	R22	R22	R22
	MAX CURRENT	A	24	30	34	48
CONDENSER	COIL	TYPE	Fin-Tube	Fin-Tube	Fin-Tube	Fin-Tube
		QTY	2	2	2	2
	FAN	MODEL	71	71	80	80
		QTY	2	2	2	2
		RPM	900	900	900	900
EVAPORATOR	TYPE	Shell-Tube	Shell-Tube	Shell-Tube	Shell-Tube	Shell-Tube
	WATER VOLUME	Lit	27	42	75	105
	FLOW RATE	Lit/min	136	180	226	270
UNIT DIMENSION	L	Cm	250	250	250	250
	W	Cm	115	115	115	115
	H	Cm	220	220	220	220
CONNECTION	INLET/OUTLET	In	1-1/2	2	2	2-1/2
ELECTRICAL DATA	VOLTAGE	V	380	380	380	380
	MAX POWER INPUT	KW	15	18	22	28
	MAX CURRENT	A	30	36	40	52

CAPACITY CORRECTION OF AIR COOLED CHILLER		Air Temperature Over Condenser Coil (T Ambient) F								
		95 (35C)			100 (38C)			105 (40C)		
		Power Input (KW)	Cooling Capacity (KW)	GPM	Power Input (KW)	Cooling Capacity (KW)	GPM	Power Input (KW)	Cooling Capacity (KW)	GPM
AIR COOLED CHILLER	MSC22015	11	45	31	12	43	30	12	43	29
	MSC22020	15	60	41	16	58	40	16	57	39
	MSC22025	16	68	47	18	66	45	18	65	44
	MSC22030	22	88	60	24	85	58	25	83	57

Chiller

MODEL : HEAVY- SEMI HERMETIC- R22
AIR COOLED CHILLER

- Capacity : 20- 160 Ton (Nominal)
- Compressor : Semi Hermetic- Bitzer Or Same
- Condenser : Air Cooled
- Fan : Zilabeg Or Same
- Evaporator : Shell & Tube
- Expansion Valve : Thermostatic, Electronic

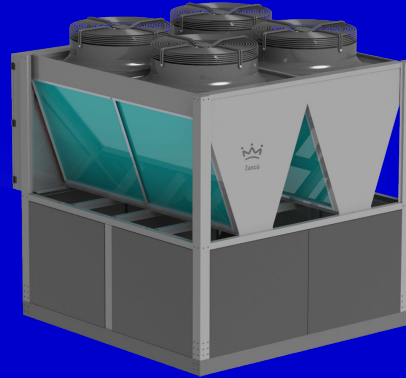

MODEL : Heavy- Semi Hermetic- R22		UNIT	HSE22020	HSE22040	HSE22050	HSE22060	HSE22075
CAPACITY	COOLING	KW	62.6	102.0	135.4	156.6	203.0
		TON	17.8	29.0	38.5	44.5	57.7
COMPRESSOR	TYPE	SEMI HERMETIC	2 Circuit	2 Circuit	2 Circuit	2 Circuit	2 Circuit
	QTY	-	2	2	2	2	2
	BRAND	-	Bitzer	Bitzer	Bitzer	Bitzer	Bitzer
	MODEL	S.H	4VE-10-40P	4NE-20-40P	4HE-25-40P	6GE-40-40P 4NE-20-40P	6FE-50-40P 4HE-25-40P
	REFRIGERANT	TYPE	R22	R22	R22	R22	R22
	MAX CURRENT	A	32	48	65.2	78	100
	CONDENSER	COIL	TYPE	Fin-Tube	Fin-Tube	Fin-Tube	Fin-Tube
QTY			2	4	4	6	6
FAN		MODEL	80	80	80	80	80
		QTY	2	4	4	6	6
		RPM	900	900	900	900	900
EVAPORATOR	TYPE	Shell-Tube	Shell-Tube	Shell-Tube	Shell-Tube	Shell-Tube	
	WATER VOLUME	Lit	50	95	115	125	150
	FLOW RATE	Lit/min	180	360	450	540	630
UNIT DIMENSION	L	Cm	220	220	220	350	350
	W	Cm	110	220	220	220	220
	H	Cm	180	180	180	180	180
CONNECTION	INLET/OUTLET	In	2	3	3	3	4
ELECTRICAL DATA	VOLTAGE	V	380	380	380	380	380
	MAX POWER INPUT	KW	22	35	45	55	68
	MAX CURRENT	A	38	52	72	88	115

CAPACITY CORRECTION OF AIR COOLED CHILLER		Air Temperture Over Condenser Coil (T Ambient) F								
		95 (35C)			100 (38C)			105 (40C)		
		Power Input (KW)	Cooling Capacity (KW)	GPM	Power Input (KW)	Cooling Capacity (KW)	GPM	Power Input (KW)	Cooling Capacity (KW)	GPM
AIR COOLED CHILLER	HSE22020	16	63	43	17	60	41	17	59	40
	HSE22040	26	102	70	27	98	67	28	96	65
	HSE22050	35	135	92	37	130	89	38	127	87
	HSE22060	40	157	107	42	151	103	43	147	101
	HSE22075	53	203	139	56	196	134	57	191	130

Chiller

MODEL : HEAVY- SEMI HERMETIC- R22
AIR COOLED CHILLER

- Capacity : 20- 160 Ton (Nominal)
- Compressor : Semi Hermetic- Bitzer Or Same
- Condenser : Air Cooled
- Fan : Zilabeg Or Same
- Evaporator : Shell & Tube
- Expansion Valve : Thermostatic, Electronic

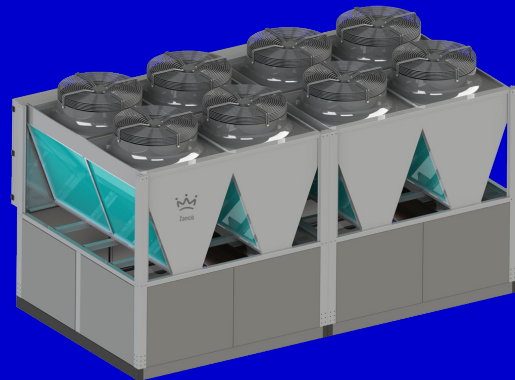

MODEL : Heavy- Semi Hermetic- R22		UNIT	HSE22085	HSE22100	HSE22120	HSE22140	HSE22160
CAPACITY	COOLING	KW	233.0	280.2	328.1	376.0	466.0
		TON	66.2	79.7	93.3	106.9	132.5
COMPRESSOR	TYPE	SEMI HERMETIC	2 Circuit	2 Circuit	2 Circuit	2 Circuit	2 Circuit
	QTY	-	2	2	2	2	4
	BRAND	-	Bitzer	Bitzer	Bitzer	Bitzer	Bitzer
	MODEL	S.H	6GE-40-40P	6FE-50-40P	8FE-70-40P 6FE-50-40P	8FE-70-40P	6GE-40-40P
	REFRIGERANT	TYPE	R22	R22	R22	R22	R22
	MAX CURRENT	A	116.8	156	188	220	168
CONDENSER	COIL	TYPE	Fin-Tube	Fin-Tube	Fin-Tube	Fin-Tube	Fin-Tube
		QTY	8	8	10	12	12
	FAN	MODEL	80	80	80	80	80
		QTY	8	8	10	12	12
		RPM	900	900	900	900	900
EVAPORATOR	TYPE	Shell-Tube	Shell-Tube	Shell-Tube	Shell-Tube	Shell-Tube	
	WATER VOLUME	Lit	175	230	245	280	300
	FLOW RATE	Lit/min	720	900	1088	1270	1630
UNIT DIMENSION	L	Cm	450	450	550	650	650
	W	Cm	220	220	220	220	220
	H	Cm	180	180	180	180	180
CONNECTION	INLET/OUTLET	In	4	4	5	5	5
ELECTRICAL DATA	VOLTAGE	V	380	380	380	380	380
	MAX POWER INPUT	KW	78	90	115	125	140
	MAX CURRENT	A	125	168	200	230	180

CAPACITY CORRECTION OF AIR COOLED CHILLER		Air Temperture Over Condenser Coil (T Ambient) F								
		95 (35C)			100 (38C)			105 (40C)		
		Power Input (KW)	Cooling Capacity (KW)	GPM	Power Input (KW)	Cooling Capacity (KW)	GPM	Power Input (KW)	Cooling Capacity (KW)	GPM
AIR COOLED CHILLER	HSE22085	61	233	159	63	225	153	65	219	150
	HSE22100	74	280	191	77	270	185	79	264	180
	HSE22120	93	328	224	97	316	216	100	308	210
	HSE22140	113	376	257	117	362	247	121	353	241
	HSE22160	121	466	318	127	449	307	130	438	299

Chiller

MODEL : HEAVY- SEMI HERMETIC- R134A
AIR COOLED CHILLER

- Capacity : 30- 140 Ton (Nominal)
- Compressor : Semi Hermetic- Bitzer Or Same
- Condenser : Air Cooled
- Fan : Zilabeg Or Same
- Evaporator : Shell & Tube
- Expansion Valve : Thermostatic, Electronic

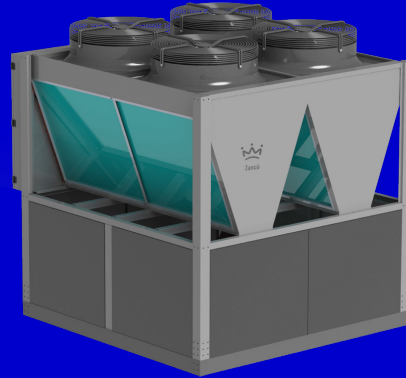

MODEL : Heavy- Semi Hermetic- R134a		UNIT	HSE34030	HSE34060	HSE34070	HSE34110	HSE34120	HSE34140
CAPACITY	COOLING	KW	54.8	121.2	128.2	192.3	239.0	256.4
		TON	15.6	34.5	36.5	54.7	68.0	72.9
COMPRESSOR	TYPE	SEMI HERMETIC	2 Circuit	2 Circuit	2 Circuit	2 Circuit	2 Circuit	2 Circuit
	QTY	-	2	2	2	3	2	4
	BRAND	-	Bitzer	Bitzer	Bitzer	Bitzer	Bitzer	Bitzer
	MODEL	S.H	4PE-15Y-40P	4FE-28Y-40P	6HE-35Y-40P	6HE-35Y-40P	8FE-60Y-40P	6HE-35Y-40P
	REFRIGERANT	TYPE	R134a	R134a	R134a	R134a	R134a	R134a
	MAX CURRENT	A	30.4	65	70	100	125	140
CONDENSER	COIL	TYPE	Fin-Tube	Fin-Tube	Fin-Tube	Fin-Tube	Fin-Tube	Fin-Tube
		QTY	2	4	4	6	8	8
	FAN	MODEL	80	80	80	80	80	80
		QTY	2	4	4	6	8	8
		RPM	900	900	900	900	900	900
EVAPORATOR	TYPE	Shell-Tube	Shell-Tube	Shell-Tube	Shell-Tube	Shell-Tube	Shell-Tube	Shell-Tube
	WATER VOLUME	Lit	50	100	115	150	160	180
	FLOW RATE	Lit/min	180	360	450	630	820	900
UNIT DIMENSION	L	Cm	220	250	250	350	450	450
	W	Cm	110	220	220	220	220	220
	H	Cm	180	180	180	180	180	180
CONNECTION	INLET/OUTLET	In	2	3	3	3	4	4
ELECTRICAL DATA	VOLTAGE	V	380	380	380	380	380	380
	MAX POWER INPUT	KW	20	42	45	62	80	85
	MAX CURRENT	A	35	72	78	110	130	152

CAPACITY CORRECTION OF AIR COOLED CHILLER		Air Temperature Over Condenser Coil (T Ambient) F								
		95 (35C)			100 (38C)			105 (40C)		
		Power Input (KW)	Cooling Capacity (KW)	GPM	Power Input (KW)	Cooling Capacity (KW)	GPM	Power Input (KW)	Cooling Capacity (KW)	GPM
AIR COOLED CHILLER	HSE34030	14	55	37	15	52	36	15	50	34
	HSE34060	33	121	83	35	116	79	35	113	77
	HSE34070	34	128	87	35	123	84	36	119	81
	HSE34110	50	192	131	52	184	125	53	178	122
	HSE34120	70	239	163	72	228	156	74	221	151
	HSE34140	67	256	175	70	245	167	71	238	162

Chiller

MODEL : HEAVY- SCROLL- R22
AIR COOLED CHILLER

- Capacity : 40- 180 Ton (Nominal)
- Compressor : Scroll- Copeland, Danfoss
- Condenser : Air Cooled
- Fan : Zilabeg Or Same
- Evaporator : Shell & Tube
- Expansion Valve : Thermostatic, Electronic

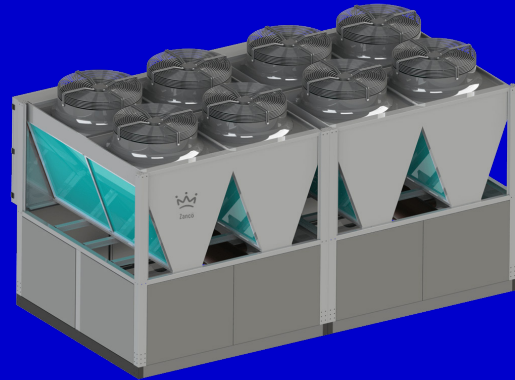

MODEL : Heavy- Scroll- R134a		UNIT	HSC22040	HSC22050	HSC22060	HSC22070	HSC22080
CAPACITY	COOLING	KW	114.2	142.4	176.0	199.5	228.4
		TON	32.5	40.5	50.0	56.7	64.9
COMPRESSOR	TYPE	SCROLL	2 Circuit	2 Circuit	2 Circuit	2 Circuit	2 Circuit
	QTY	-	2	2	2	3	4
	BRAND	-	Copeland	Copeland	Copeland	Copeland	Copeland
	MODEL	ZR	ZR250	ZR310	ZR380	2* ZR310 1* ZR250	ZR250
	REFRIGERANT	TYPE	R22-R407C	R22-R407C	R22-R407C	R22-R407C	R22-R407C
	MAX CURRENT	A	56	72	86	100	112
CONDENSER	COIL	TYPE	Fin-Tube	Fin-Tube	Fin-Tube	Fin-Tube	Fin-Tube
		QTY	4	4	6	6	8
	FAN	MODEL	80	80	80	80	80
		QTY	4	4	6	6	8
		RPM	900	900	900	900	900
EVAPORATOR	TYPE	Shell-Tube	Shell-Tube	Shell-Tube	Shell-Tube	Shell-Tube	
	WATER VOLUME	Lit	100	115	107	150	175
	FLOW RATE	Lit/ min	360	450	544	635	725
UNIT DIMENSION	L	Cm	220	220	330	330	450
	W	Cm	220	220	220	220	220
	H	Cm	180	180	180	180	180
CONNECTION	INLET/OUTLET	In	3	3	3	3	4
ELECTRICAL DATA	VOLTAGE	V	380	380	380	380	380
	MAX POWER INPUT	KW	37	45	52	63	74
	MAX CURRENT	A	60	76	90	110	125

CAPACITY CORRECTION OF AIR COOLED CHILLER		Air Temperature Over Condenser Coil (T Ambient) F								
		95 (35C)			100 (38C)			105 (40C)		
		Power Input (KW)	Cooling Capacity (KW)	GPM	Power Input (KW)	Cooling Capacity (KW)	GPM	Power Input (KW)	Cooling Capacity (KW)	GPM
AIR COOLED CHILLER	HSC22040	29	114	78	31	111	76	32	109	74
	HSC22050	36	142	97	38	138	94	40	135	92
	HSC22060	44	176	120	47	171	117	49	168	114
	HSC22070	51	200	136	54	194	132	56	189	129
	HSC22080	58	228	156	62	222	151	64	218	148

Chiller

MODEL : HEAVY- SCROLL- R22
AIR COOLED CHILLER

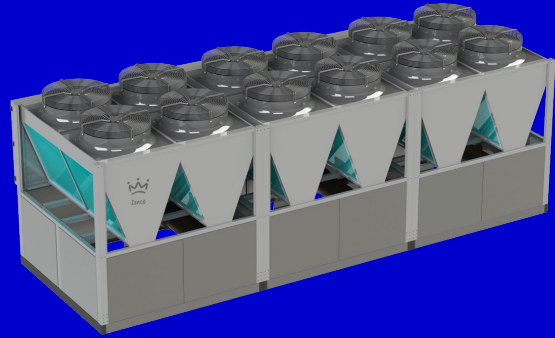

- Capacity : 40- 180 Ton (Nominal)
- Compressor : Scroll- Copeland, Danfoss
- Condenser : Air Cooled
- Fan : Zilabeg Or Same
- Evaporator : Shell & Tube
- Expansion Valve : Thermostatic, Electronic

MODEL : Heavy- Scroll- R22		UNIT	HSC22100	HSC22120	HSC22140	HSC22160	HSC22180
CAPACITY	COOLING	KW	285.5	356.0	427.2	456.8	528.0
		TON	81.2	101.2	121.5	129.9	150.1
COMPRESSOR	TYPE	SCROLL	2 Circuit	2 Circuit	2 Circuit	2 Circuit	2 Circuit
	QTY	-	5	5	6	8	6
	BRAND	-	Copeland	Copeland	Copeland	Copeland	Copeland
	MODEL	ZR	ZR250	ZR310	ZR310	ZR250	ZR380
	REFRIGERANT	TYPE	R22-R407C	R22-R407C	R22-R407C	R22-R407C	R22-R407C
	MAX CURRENT	A	140	180	216	224	258
CONDENSER	COIL	TYPE	Fin-Tube	Fin-Tube	Fin-Tube	Fin-Tube	Fin-Tube
		QTY	10	10	12	12	16
	FAN	MODEL	80	80	80	80	80
		QTY	10	10	12	12	16
		RPM	900	900	900	900	900
EVAPORATOR	TYPE	Shell-Tube	Shell-Tube	Shell-Tube	Shell-Tube	Shell-Tube	
	WATER VOLUME	Lit	236	212	287	264	350
	FLOW RATE	Lit/ min	910	1088	1270	1451	1630
UNIT DIMENSION	L	Cm	550	550	660	660	770
	W	Cm	220	220	220	220	220
	H	Cm	180	180	180	180	180
CONNECTION	INLET/OUTLET	In	4	5	5	5	6
ELECTRICAL DATA	VOLTAGE	V	380	380	380	380	380
	MAX POWER INPUT	KW	90	115	135	145	165
	MAX CURRENT	A	150	200	230	240	280

CAPACITY CORRECTION OF AIR COOLED CHILLER		Air Temperture Over Condenser Coil (T Ambient) F								
		95 (35C)			100 (38C)			105 (40C)		
		Power Input (KW)	Cooling Capacity (KW)	GPM	Power Input (KW)	Cooling Capacity (KW)	GPM	Power Input (KW)	Cooling Capacity (KW)	GPM
AIR COOLED CHILLER	HSC22100	73	286	195	77	278	189	81	272	186
	HSC22120	90	356	243	96	345	235	100	337	230
	HSC22140	108	427	292	115	414	283	120	404	276
	HSC22160	116	457	312	124	444	303	129	435	297
	HSC22180	133	528	360	140	513	350	146	503	343

Chiller

MODEL : HEAVY- SCROLL- R134A
AIR COOLED CHILLER

- Capacity : 20- 160 Ton (Nominal)
- Compressor : Scroll- Copeland, Danfoss
- Condenser : Air Cooled
- Fan : Zilabeg Or Same
- Evaporator : Shell & Tube
- Expansion Valve : Thermostatic, Electronic

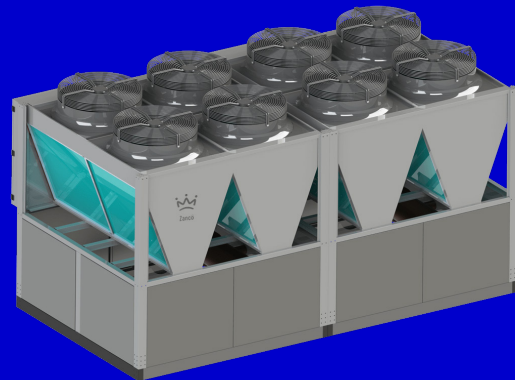

MODEL : Heavy- Scroll- R134a		UNIT	HSC34020	HSC34040	HSC34060	HSC34080
CAPACITY	COOLING	KW	58.6	115.4	173.1	230.8
		TON	16.7	32.8	49.2	65.6
COMPRESSOR	TYPE	SCROLL	2 Circuit	2 Circuit	2 Circuit	2 Circuit
	QTY	-	2	2	3	4
	BRAND	-	Copeland	Copeland	Copeland	Copeland
	MODEL	ZR	ZR190	ZR380	ZR380	ZR380
	REFRIGERANT	TYPE	R134a	R134a	R134a	R134a
	MAX CURRENT	A	44	64	96	128
CONDENSER	COIL	TYPE	Fin-Tube	Fin-Tube	Fin-Tube	Fin-Tube
		QTY	2	4	6	8
	FAN	MODEL	80	80	80	80
		QTY	2	4	6	8
		RPM	900	900	900	900
EVAPORATOR	TYPE	Shell-Tube	Shell-Tube	Shell-Tube	Shell-Tube	
	WATER VOLUME	Lit	50	95	110	126
	FLOW RATE	Lit/min	180	360	540	725
UNIT DIMENSION	L	Cm	220	220	350	450
	W	Cm	110	220	220	220
	H	Cm	180	180	180	180
CONNECTION	INLET/OUTLET	In	3	3	3	4
ELECTRICAL DATA	VOLTAGE	V	380	380	380	380
	MAX POWER INPUT	KW	20	38	58	75
	MAX CURRENT	A	50	70	100	136

CAPACITY CORRECTION OF AIR COOLED CHILLER		Air Temperture Over Condenser Coil (T Ambient) F								
		95 (35C)			100 (38C)			105 (40C)		
		Power Input (KW)	Cooling Capacity (KW)	GPM	Power Input (KW)	Cooling Capacity (KW)	GPM	Power Input (KW)	Cooling Capacity (KW)	GPM
AIR COOLED CHILLER	HSC34020	16	59	40	16	56	38	17	55	38
	HSC34040	30	115	79	32	112	76	33	109	75
	HSC34060	45	173	118	48	167	114	50	164	112
	HSC34080	60	231	157	64	223	152	66	218	149

Chiller

MODEL : HEAVY- SCROLL- R134A
AIR COOLED CHILLER

- Capacity : 20- 160 Ton (Nominal)
- Compressor : Scroll- Copeland, Danfoss
- Condenser : Air Cooled
- Fan : Zilabeg Or Same
- Evaporator : Shell & Tube
- Expansion Valve : Thermostatic, Electronic

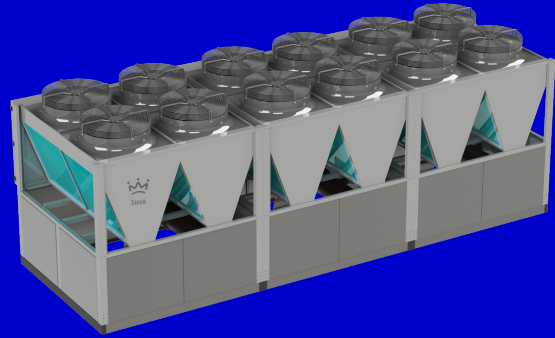

MODEL : Heavy- Scroll- R134a		UNIT	HSC34100	HSC34120	HSC34140	HSC34160
CAPACITY	COOLING	KW	288.5	346.2	403.9	461.6
		TON	82.0	98.4	114.8	131.2
COMPRESSOR	TYPE	SCROLL	2 Circuit	2 Circuit	2 Circuit	2 Circuit
	QTY	-	5	6	7	8
	BRAND	-	Copeland	Copeland	Copeland	Copeland
	MODEL	ZR	ZR380	ZR380	ZR380	ZR380
	REFRIGERANT	TYPE	R134a	R134a	R134a	R134a
	MAX CURRENT	A	160	192	224	256
CONDENSER	COIL	TYPE	Fin-Tube	Fin-Tube	Fin-Tube	Fin-Tube
		QTY	10	12	14	16
	FAN	MODEL	80	80	80	80
		QTY	10	12	14	16
		RPM	900	900	900	900
EVAPORATOR	TYPE	Shell-Tube	Shell-Tube	Shell-Tube	Shell-Tube	Shell-Tube
	WATER VOLUME	Lit	150	210	190	250
	FLOW RATE	Lit/min	900	1088	1270	1450
UNIT DIMENSION	L	Cm	550	650	750	850
	W	Cm	220	220	220	220
	H	Cm	180	180	180	180
CONNECTION	INLET/OUTLET	In	4	5	5	5
ELECTRICAL DATA	VOLTAGE	V	380	380	380	380
	MAX POWER INPUT	KW	95	120	130	145
	MAX CURRENT	A	170	200	240	260

CAPACITY CORRECTION OF AIR COOLED CHILLER		Air Temperture Over Condenser Coil (T Ambient) F								
		95 (35C)			100 (38C)			105 (40C)		
		Power Input (KW)	Cooling Capacity (KW)	GPM	Power Input (KW)	Cooling Capacity (KW)	GPM	Power Input (KW)	Cooling Capacity (KW)	GPM
AIR COOLED CHILLER	HSC34100	75	289	197	80	279	190	83	273	186
	HSC34120	90	346	236	96	335	228	100	328	224
	HSC34140	105	404	276	112	391	267	116	382	261
	HSC34160	120	462	315	128	446	305	133	437	298

Chiller

MODEL : HEAVY- SCREW- R22
AIR COOLED CHILLER

- Capacity : 50- 250 Ton (Nominal)
- Compressor : Screw- Bitzer, Hanbel Or Same
- Condenser : Air Cooled
- Fan : Zilabeg
- Evaporator : Shell & Tube
- Expansion Valve : Electronic

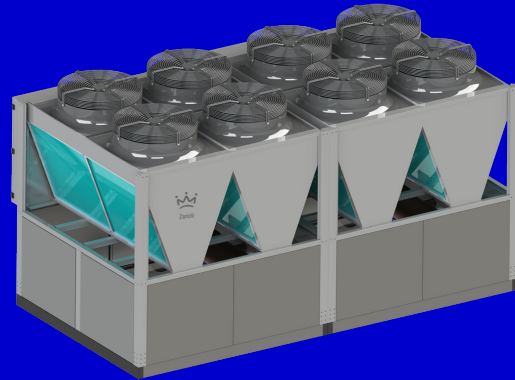

MODEL : Heavy- Screw - R22		UNIT	HSW22050	HSW22060	HSW22070	HSW22080	HSW22090	HSW22100
CAPACITY	COOLING	KW	132.1	166.0	194.0	226.3	269.2	298.7
		TON	37.6	47.2	55.1	64.4	76.5	84.9
COMPRESSOR	TYPE	SCREW	1 Circuit	1 Circuit	1 Circuit	1,2 Circuit	1,2 Circuit	1,2 Circuit
	QTY	-	1	1	1	1,2	1,2	1,2
	BRAND	-	Bitzer	Bitzer	Bitzer	Bitzer	Bitzer	Bitzer
	MODEL	CSH	6553-50-40P	6563-60-40P	7553-70-40P	7563-80-40P	7573-90-40P	7583-100-40P
	REFRIGERANT	TYPE	R22	R22	R22	R22	R22	R22
	MAX CURRENT	A	54	67	80	90	98	113
CONDENSER	COIL	TYPE	Fin-Tube	Fin-Tube	Fin-Tube	Fin-Tube	Fin-Tube	Fin-Tube
		QTY	4	6	6	8	8	10
	FAN	MODEL	80	80	80	80	80	80
		QTY	4	6	6	8	8	10
		RPM	900	900	900	900	900	900
EVAPORATOR	TYPE	Shell-Tube	Shell-Tube	Shell-Tube	Shell-Tube	Shell-Tube	Shell-Tube	
	WATER VOLUME	Lit	115	120	150	170	190	230
	FLOW RATE	Lit/min	450	560	630	720	820	900
UNIT DIMENSION	L	Cm	220	350	350	450	450	550
	W	Cm	220	220	220	220	220	220
	H	Cm	180	180	180	180	180	180
CONNECTION	INLET/OUTLET	In	3	3	3	4	4	4
ELECTRICAL DATA	VOLTAGE	V	380	380	380	380	380	380
	MAX POWER INPUT	KW	35	42	50	58	68	78
	MAX CURRENT	A	60	72	90	100	110	122

CAPACITY CORRECTION OF AIR COOLED CHILLER		Air Temperature Over Condenser Coil (T Ambient) F								
		95 (35C)			100 (38C)			105 (40C)		
		Power Input (KW)	Cooling Capacity (KW)	GPM	Power Input (KW)	Cooling Capacity (KW)	GPM	Power Input (KW)	Cooling Capacity (KW)	GPM
AIR COOLED CHILLER	HSW22050	28	132	90	29	128	87	31	124	85
	HSW22060	34	166	113	36	161	110	38	156	106
	HSW22070	42	194	132	44	188	128	46	182	124
	HSW22080	48	226	154	50	219	149	52	212	144
	HSW22090	55	269	184	57	261	178	60	253	173
	HSW22100	64	299	204	66	289	197	69	280	191

Chiller

MODEL : HEAVY- SCREW- R22
AIR COOLED CHILLER

- Capacity : 50- 250 Ton (Nominal)
- Compressor : Screw- Bitzer, Hanbel Or Same
- Condenser : Air Cooled
- Fan : Zilabeg
- Evaporator : Shell & Tube
- Expansion Valve : Electronic

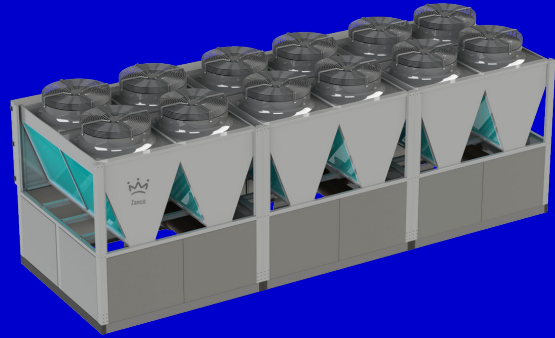

MODEL : Heavy- Screw- R22		UNIT	HSW22125	HSW22140	HSW22180	HSW22220	HSW22250
CAPACITY	COOLING	KW	370.4	427.3	558.0	656.0	758.6
		TON	105.3	121.5	158.6	186.5	215.7
COMPRESSOR	TYPE	SCREW	1,2 Circuit	1,2 Circuit	1,2 Circuit	1,2 Circuit	1,2 Circuit
	QTY	-	1,2	1,2	1,2	1,2	1,2
	BRAND	-	Bitzer	Bitzer	Bitzer	Bitzer	Bitzer
	MODEL	CSH	8563-125-40P	8573-140-40P	9553-180-40D	9563-210-40D	9573-240-40D
	REFRIGERANT	TYPE	R22	R22	R22	R22	R22
	MAX CURRENT	A	141	170	212	237	264
CONDENSER	COIL	TYPE	Fin-Tube	Fin-Tube	Fin-Tube	Fin-Tube	Fin-Tube
		QTY	10	12	14	18	20
	FAN	MODEL	80	80	80	80	80
		QTY	10	12	14	18	20
		RPM	900	900	900	900	900
EVAPORATOR	TYPE	Shell-Tube	Shell-Tube	Shell-Tube	Shell-Tube	Shell-Tube	
	WATER VOLUME	Lit	230	280	260	300	320
	FLOW RATE	Lit/min	1088	1270	1450	1815	2100
UNIT DIMENSION	L	Cm	550	650	750	850	1200
	W	Cm	220	220	220	220	220
	H	Cm	180	180	180	180	180
CONNECTION	INLET/OUTLET	In	5	5	6	6	6
ELECTRICAL DATA	VOLTAGE	V	380	380	380	380	380
	MAX POWER INPUT	KW	90	112	135	155	170
	MAX CURRENT	A	155	185	225	250	280

CAPACITY CORRECTION OF AIR COOLED CHILLER		Air Temperture Over Condenser Coil (T Ambient) F								
		95 (35C)			100 (38C)			105 (40C)		
		Power Input (KW)	Cooling Capacity (KW)	GPM	Power Input (KW)	Cooling Capacity (KW)	GPM	Power Input (KW)	Cooling Capacity (KW)	GPM
AIR COOLED CHILLER	HSW22125	77	370	253	79	359	245	83	347	236
	HSW22140	94	427	292	97	417	284	101	406	277
	HSW22180	113	558	381	118	544	371	123	529	361
	HSW22220	133	656	448	137	639	436	143	621	424
	HSW22250	148	759	518	154	737	503	161	715	488

Chiller

MODEL : HEAVY- SCREW- R134A
AIR COOLED CHILLER

- Capacity : 60- 320 Ton (Nominal)
- Compressor : Screw- Bitzer, Hanbel Or Same
- Condenser : Air Cooled
- Fan : Zilabeg
- Evaporator : Shell & Tube
- Expansion Valve : Thermostatic

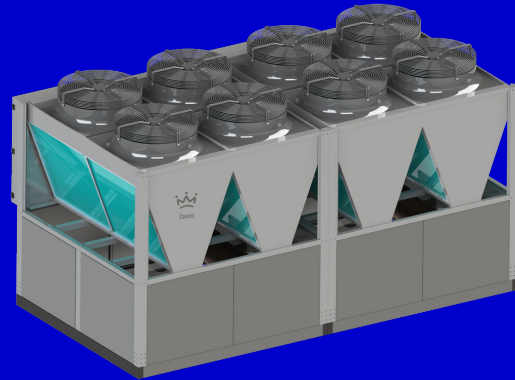

MODEL : Heavy- Screw- R134a		UNIT	HSW34060	HSW34090	HSW34110	HSW34125	HSW34140	HSW34160
CAPACITY	COOLING	KW	133.7	157.7	209.0	243.0	276.0	302.0
		TON	38.0	44.8	59.4	69.1	78.5	85.9
COMPRESSOR	TYPE	SCREW	1 Circuit	1 Circuit	1 Circuit	1,2 Circuit	1,2 Circuit	1,2 Circuit
	QTY	-	1	1	1	1,2	1,2	1,2
	BRAND	-	Bitzer	Bitzer	Bitzer	Bitzer	Bitzer	Bitzer
	MODEL	CSH	6593-60Y-40P	7573-90Y-40P	9553-180Y-40P	8563-125Y-40P	8573-140Y-40P	8583-160Y-40P
	REFRIGERANT	TYPE	R134A	R134A	R134A	R134A	R134A	R134A
	MAX CURRENT	A	63	76	100	122	135	150
CONDENSER	COIL	TYPE	Fin-Tube	Fin-Tube	Fin-Tube	Fin-Tube	Fin-Tube	Fin-Tube
		QTY	4	6	6	8	8	10
	FAN	MODEL	80	80	80	80	80	80
		QTY	4	6	6	8	8	10
		RPM	900	900	900	900	900	900
EVAPORATOR	TYPE	Shell-Tube	Shell-Tube	Shell-Tube	Shell-Tube	Shell-Tube	Shell-Tube	
	WATER VOLUME	Lit	115	125	150	175	230	240
	FLOW RATE	Lit/min	450	550	650	850	900	950
UNIT DIMENSION	L	Cm	220	350	350	450	450	550
	W	Cm	220	220	220	220	220	220
	H	Cm	180	180	180	180	180	180
CONNECTION	INLET/OUTLET	In	3	3	3	4	4	4
ELECTRICAL DATA	VOLTAGE	V	380	380	380	380	380	380
	MAX POWER INPUT	KW	40	50	65	78	88	98
	MAX CURRENT	A	68	82	110	130	148	160

CAPACITY CORRECTION OF AIR COOLED CHILLER		Air Temperature Over Condenser Coil (T Ambient) F								
		95 (35C)			100 (38C)			105 (40C)		
		Power Input (KW)	Cooling Capacity (KW)	GPM	Power Input (KW)	Cooling Capacity (KW)	GPM	Power Input (KW)	Cooling Capacity (KW)	GPM
AIR COOLED CHILLER	HSW34060	32	134	91	34	128	87	36	124	85
	HSW34090	40	158	108	42	151	103	44	147	100
	HSW34110	52	209	143	55	201	137	58	195	133
	HSW34125	62	243	166	66	239	163	69	235	160
	HSW34140	69	276	188	74	270	184	78	266	182
	HSW34160	79	302	206	84	296	202	88	291	199

Chiller

MODEL : HEAVY- SCREW- R134A
AIR COOLED CHILLER

- Capacity : 60- 320 Ton (Nominal)
- Compressor : Screw- Bitzer, Hanbel Or Same
- Condenser : Air Cooled
- Fan : Zilabeg
- Evaporator : Shell & Tube
- Expansion Valve : Thermostatic

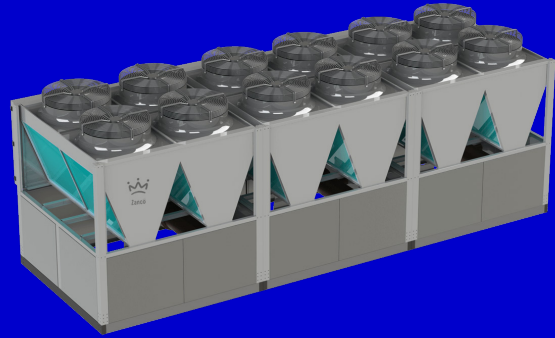

MODEL : Heavy- Screw- R134a		UNIT	HSW34180	HSW34210	HSW34240	HSW34280	HSW34320
CAPACITY	COOLING	KW	346.0	410.0	466.0	662.0	696.0
		TON	98.4	116.6	132.5	188.2	197.9
COMPRESSOR	TYPE	SCREW	1,2 Circuit	1,2 Circuit	1,2 Circuit	1,2 Circuit	1,2 Circuit
	QTY	-	1,2	1,2	1,2	1,2	1,2
	BRAND	-	Bitzer	Bitzer	Bitzer	Bitzer	Bitzer
	MODEL	CSH	8593-180Y-40P	9563-210Y-40D	9573-240Y-40D	95103-280Y-40D	95113-320Y-40D
	REFRIGERANT	TYPE	R134A	R134A	R134A	R134A	R134A
	MAX CURRENT	A	178	196	218	309	323
CONDENSER	COIL	TYPE	Fin-Tube	Fin-Tube	Fin-Tube	Fin-Tube	Fin-Tube
		QTY	10	12	14	18	20
	FAN	MODEL	80	80	80	80	80
		QTY	10	12	14	18	20
		RPM	900	900	900	900	900
EVAPORATOR	TYPE	Shell-Tube	Shell-Tube	Shell-Tube	Shell-Tube	Shell-Tube	
	WATER VOLUME	Lit	220	280	260	280	300
	FLOW RATE	Lit/min	1088	1270	1450	1820	1950
UNIT DIMENSION	L	Cm	550	650	750	1000	1150
	W	Cm	220	220	220	220	220
	H	Cm	180	180	180	180	180
CONNECTION	INLET/OUTLET	In	5	5	6	6	6
ELECTRICAL DATA	VOLTAGE	V	380	380	380	380	380
	MAX POWER INPUT	KW	115	130	145	210	220
	MAX CURRENT	A	195	210	235	325	350

CAPACITY CORRECTION OF AIR COOLED CHILLER		Air Temperture Over Condenser Coil (T Ambient) F								
		95 (35C)			100 (38C)			105 (40C)		
		Power Input (KW)	Cooling Capacity (KW)	GPM	Power Input (KW)	Cooling Capacity (KW)	GPM	Power Input (KW)	Cooling Capacity (KW)	GPM
AIR COOLED CHILLER	HSW34180	88	346	236	94	338	231	98	333	227
	HSW34210	103	410	280	110	400	273	115	393	268
	HSW34240	117	466	318	124	455	310	130	447	305
	HSW34280	171	662	452	181	644	439	188	632	431
	HSW34320	177	696	475	187	670	457	194	653	446

Air Cooled chiller

Typically, air-cooled chillers are installed in smaller buildings, as these systems require more ductwork than water-cooled chillers. The units also contain all of their components packaged within a single cabinet, referred to as packaged cooling unit.

Benefits:

- No cooling towers
- Better environmental stability-no water wastage
- Low maintenance costs
- Easier to operate and control-tower freezing
- Water costs avoided, especially in cities
- No water problems to deal with in case of disaster

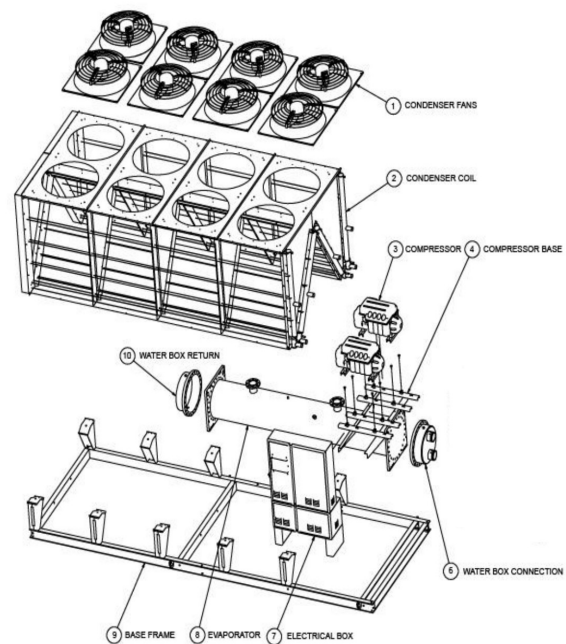
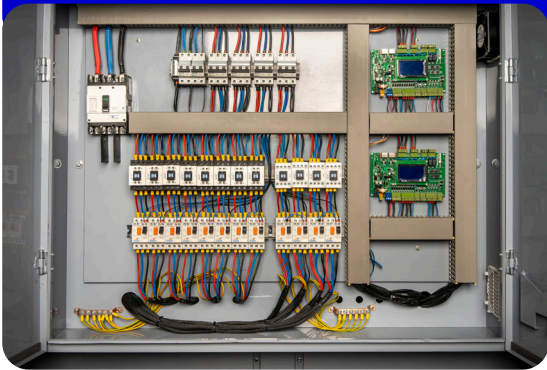

PLC Controllers:

Maximize profitability and energy efficiency through Automation control using PLC boards.

- Low and high pressure sensors
- Safety valves on refrigerating circuit
- Water temperature control sensors
- Evaporator antifreeze protection sensor
- Hygroscopic sight glasses
- Electronic expansion valves
- Service valves on the liquid line



فن کویل سقفی توکار استاندارد (سایلت) Standard Built-In Ceiling Fan Coil (Silent)



Standard Built-In Ceiling Fan Coil (Silent)

Fan Coil Unit Parameter Data
(8P-3R : Eight pipe Three Rows)



1. Nominal condition, Cooling: entering air temp 27 °C DB/19.5 °C WB; entering water temp 7°C, leaving water temp 12°C; Heating: entering air temp 21°C; entering water temp 60°C, the same water flow as that in cooling
2. Air flow is tested with standard air condition (20°C DB) and dry coil;
3. Static pressure is measured without filter and air outlet (no plenum).

UNIT			Standard Built-In Ceiling Fan Coil (Silent)							
COIL	MODEL		SDFC0200	SDFC0300	SDFC0400	SDFC0600	SDFC0800 (2fan)	SDFC0800 (3fan)	SDFC1000	SDFC1200
	AIR FLOW RATE (CFM)			200	300	400	600	800	800	1000
NOMINAL CAPACITY (BTU/H)	COOLING	TOTAL	8500	9900	12900	18300	22600	26200	28600	35200
		SENSIBLE	5800	6400	8400	12000	15100	17400	18400	23000
	HEATING		22100	23600	30600	43400	56000	64300	66700	84000
FACE AREA (SQ.FT)			0.9	1.1	1.3	1.6	1.8	2.4	2.4	2.4
WATER FLOW RATE (GPM)			2	2.5	3	4	4.5	5	6	7
PIPING CONNECTION (IN)			3/4	3/4	3/4	3/4	1	1	1	1
WATER PRESSURE DROP (PSI)			0.7	1.2	2	3.5	5	7	7	10
FIN ROW/FPI			3/12	3/12	3/12	3/12	3/12	3/12	3/12	3/12
MOTOR	POWER SUPPLY (V/Hz)		220-240/50							
	INPUT POWER (HP)		1/20	1/20	1/20	1/20	1/12	1/20+1/20	1/20+1/20	1/12
	NO OF MOTOR		1	1	1	1	1	2	2	2
	CLASS		ELECTROGEN (CLASS:A)							
	MAX RPM		1100	1100	1100	1100	1100	1100	1100	1100
FAN	TYPE		Centrifugal Fan (Metalic Forward Curved)							
	NO OF FAN		1	1	2	2	2	3	3	3
	AIR FLOW RATE (CFM)		300	300	200	300	400	300	300	400
	NOISE LEVEL (dB)		40	40	42	42	44	42	44	46
BODY	DIMENSION (L*W*H)	Cm	65*48*22	75*48*22	85*48*22	100*48*22	110*48*24	130*48*22	140*48*22	140*48*24
	NET WEIGHT (Kg)		15	17	21	24	26	30	33	37
	FILTER		Aluminium (Optional Synthetic Nylon)							
	DRAIN PAN/ CONNECTION		Galvanized / 1/2							

Standard Built-In Ceiling Fan Coil (Silent) Dimension

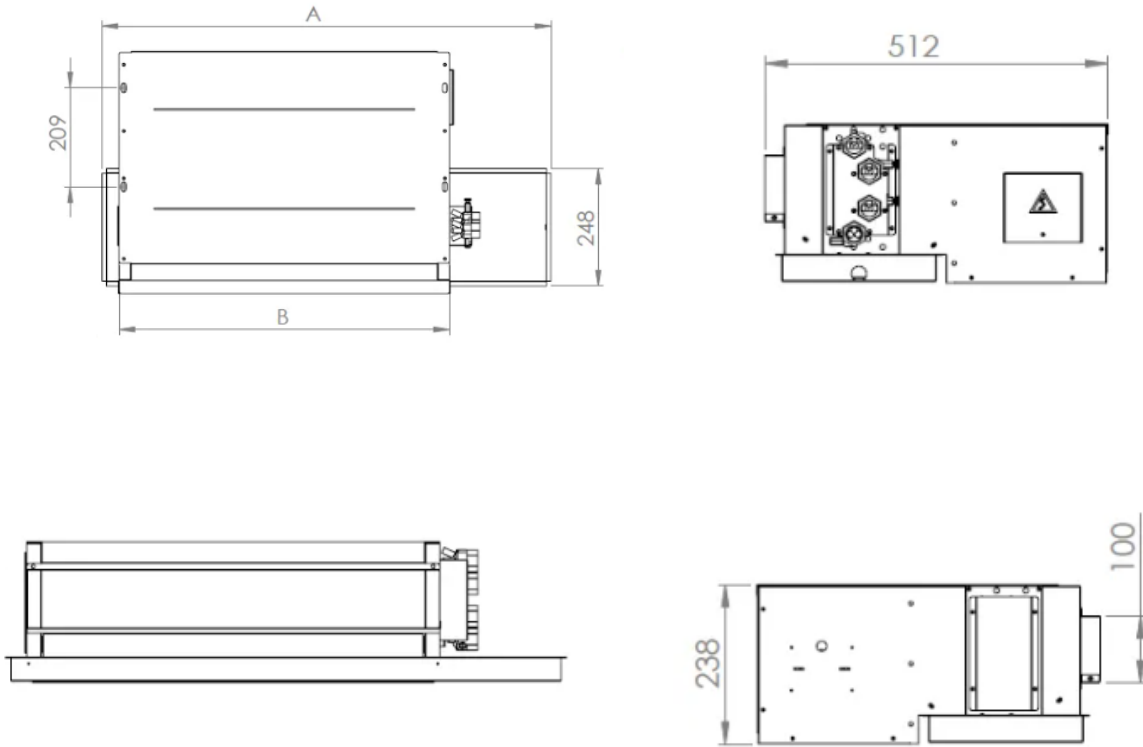

Capacity (CFM)	A (mm)	B (mm)
200	750	500
300	860	600
400	970	700
600	1120	850
800	1500	1200
1000	1500	1250
1200	1500	1250

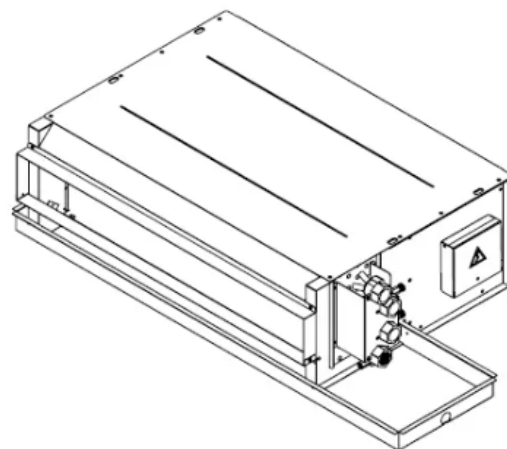

Fan coil (Design and operation)

Fan Coil Unit covers a range of products and will mean different things to users, specifies, and installers in different countries and regions, particularly in relation to product size and output capability.

- A fan coil unit may be concealed or exposed within the room or area that it serves
- A concealed fan coil unit will typically be installed within an accessible ceiling void or services zone.
- The coil receives hot or cold water from a central

plant, and removes heat from or adds heat to the air through heat transfer.

- Fan coil units are divided into two types: fan coil units or ducted fan coil units.
- The coil receives hot or cold water from a central plant, and removes heat from or adds heat to the air through heat transfer. Traditionally fan coil units can contain their own internal thermostat, or can be wired to operate with a remote thermostat.



Unique Features

1. Advanced DC motor

High efficiency DC motor | Insulation Class: B | Protection Class: IP20

2. Easy-to-access Centrifugal Fan

Easy-to-open ABS and Metal Fan volute makes service work easy and simple; high efficient large centrifugal fan ensures strong and constant air flow. Axis's and bearings have been specially treated for longer service life.

3. High Efficiency Heat Exchanger

Louvered aluminum fins and seamless copper pipes are made into this top-level heat exchanger.

4. Removable End Panel

End panels on both sides can be removed; coil connection orientation can be easily changed on site.

5. Clean Drain pan

Integrated punched drain pan is covered with 5mm PE insulation.

6. Leakage-tight Header

This safe and secure header structure is perfectly designed, aiming at totally leakage-free and durable operation.

7. Innovative Filter Rack

Slip-on type mounting rack allows quick and easy filter replacement.

8. Ultra thin

The unit height is only 200-220mm so that they can save installation space and meet the requirement of all kinds of situations.

Product Features

بدنه دستگاه از جنس گالوانیزه با ضخامت ۱ میلیمتر با کمترین لرزش
 سینی موتور گالوانیزه ۱٫۵ میلیمتر
 عایق شدن بدنه دستگاه با ۳ میلیمتر عایق حرارتی
 قابلیت اتصال کانال و دریچه به خروجی دستگاه

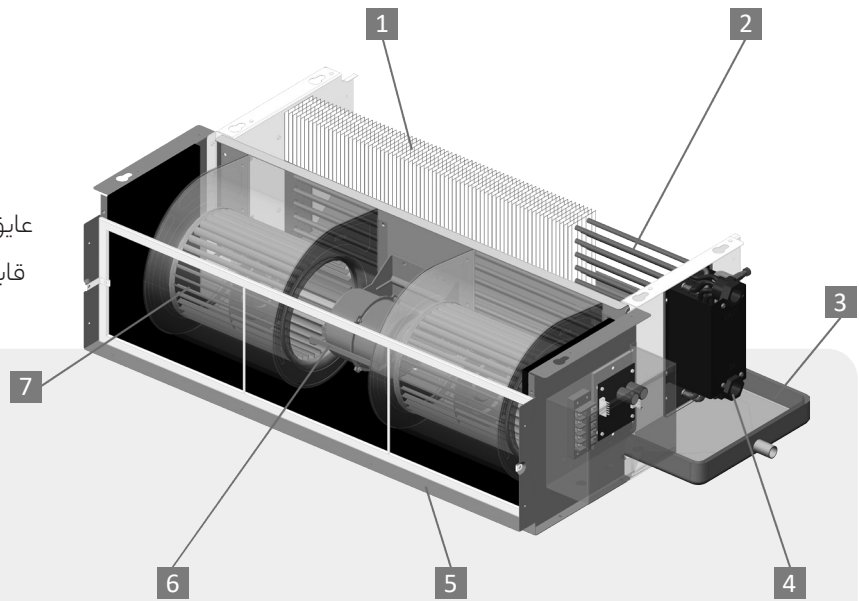

فین ها از جنس آلومینیوم با ضخامت ۱۵۰ میکرون
 انواع مختلف روکش دار (Coated) آبی و طلایی
 تراکم فین (FPI) ۱۲

1
FIN

ابعاد کویل مطابق با طراحی در ظرفیت های مختلف با ۳ ردیف لوله
 جنس لوله مسی و ضخامت لوله قابلیت تحمل فشار ۲۰ بار
 قابلیت چپ و راست شدن کویل

2
Tube

با ضخامت ۵ میلیمتر عایق
 ارتفاع ۳۰ میلیمتر از جنس گالوانیزه با پوشش رنگ الکترواستاتیک
 اتصال ۱/۲ و ۳/۴ فلزی برای ظرفیت های مختلف
 قابلیت چپ و راست شدن سینی

3
Drain

اتصالات ۳/۴ اینچ فورج شده
 پیچ متصل شده به جهت جلوگیری از پیچش هنگام نصب
 شیر هواگیری در بالاترین قسمت خروجی
 شیر تخلیه در پایین ترین قسمت ورودی

4
Connection

فیلتر دو لایه آلومینیومی قابل شستشو یا فیلتر پارچه ایی
 قابلیت جابجایی فیلتر از پشت یا پایین دستگاه
 قابلیت خارج کردن ساده فیلتر توسط اپراتور

5
Filter

موتور با پوسته آلومینیومی و انتقال حرارت بالا و قابلیت ۷ دور مختلف
 سیم اتصال به بدنه (Earth)
 پایه موتور با ضخامت بالا و جلوگیری از لرزش

6
Motor

Inlet Air

قابلیت تغییر مکش از پشت یا
 زیر دستگاه در طراحی
 صداگیری فیلتر با نوار درزگیر
 در نقاط اتصال

قابلیت نصب فن فلزی یا پلاستیکی
 استفاده از فن با ظرفیت های ۲۰۰ و ۳۰۰ و تعداد مختلف
 فشار استاتیکی ۳۰-۵۰ بار برای ظرفیت های مختلف

7
Fan

فن کویل سقفی توکار اسلیم Slim Built-In Ceiling Fan Coil



Slim Built-In Ceiling Fan Coil

DC Fan Coil Unit Parameter Data
(8P-3R : Eight pipe Three Rows)



1. Nominal condition, Cooling: entering air temp 27 °C DB/19.5 °C WB; entering water temp 7°C, leaving water temp 12°C; Heating: entering air temp 21°C; entering water temp 60°C, the same water flow as that in cooling
2. Air flow is tested with standard air condition (20°C DB) and dry coil;
3. Static pressure is measured without filter and air outlet (no plenum).

UNIT			Slim Built-In Ceiling Fan Coil						
MODEL			SLFC200	SLFC300	SLFC400	SLFC600	SLFC800	SLFC1000	SLFC1200
AIR FLOW RATE (CFM)			200	300	400	600	800	1000	1200
NOMINAL CAPACITY (BTU/H)	COOLING	TOTAL	8500	9900	12900	18300	26200	28600	35200
		SENSIBLE	5800	6400	8400	12000	17400	18400	23000
	HEATING		22100	23600	30600	43400	64300	66700	84000
FACE AREA (SQ.FT)			0.9	1.1	1.3	1.6	2.4	2.4	2.4
WATER FLOW RATE (GPM)			2	2.5	3	4	5	6	7
PIPING CONNECTION (IN)			3/4	3/4	3/4	3/4	1	1	1
FIN ROW/FPI			3/12	3/12	3/12	3/12	3/12	3/12	3/12
WATER PRESSURE DROP (PSI)			0.7	1.2	2	3.5	7	7	10
POWER SUPPLY (V/Hz)			220-240/50						
INPUT POWER (HP)			1/20	1/20	1/20	1/20	1/20+1/20	1/20+1/20	1/20+1/20
NO OF MOTOR			1	1	1	1	2	2	2
CLASS			ELECTROGEN (CLASS A- 7 Mode)						
MAX RPM			1100	1100	1100	1100	1100	1100	1100
TYPE			Centrifugal Fan (Metallic Forward Curved)						
NO OF FAN			1	1	2	2	3	3	4
AIR FLOW RATE (CFM)			300	300	200	300	300	300	300
NOISE LEVEL (dB)			40	40	42	42	42	44	46
DIMENSION (L*W*H)		Cm	67*52*21	77*52*21	87*52*21	102*52*21	132*52*21	142*52*21	152*52*21
NET WEIGHT (kg)			18	21	25	28	32	36	42
FILTER			Aluminium (Optional Synthetic Option)						
DRAIN PAN/ CONNECTION			Galvanized / 1/2						

Slim Built-In Ceiling Fan Coil Dimension

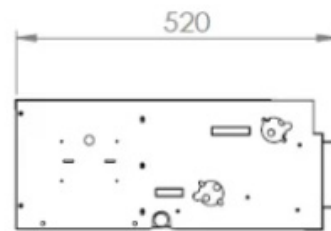
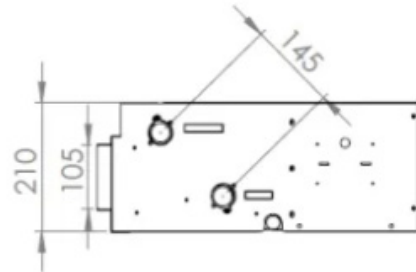
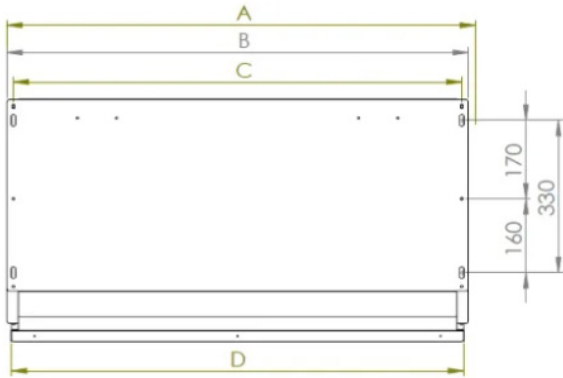

Capacity (CFM)	A (mm)	B (mm)	C (mm)	D (mm)
200	673	650	630	630
300	773	750	730	730
400	873	850	830	830
600	1023	1000	980	980
800	1323	1300	1280	1280
1000	1423	1400	1380	1380
1200	1523	1500	1480	1480

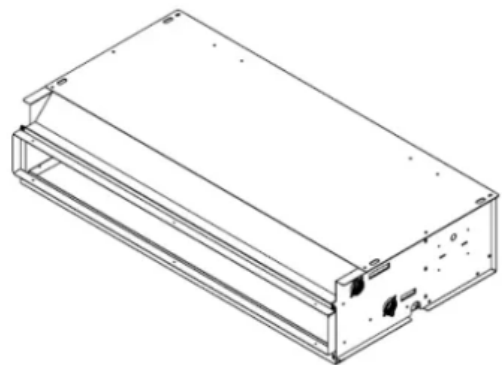

Fan Coil Unit

Slim Built-In Ceiling Fan Coil

Capacity: 200-1200 CFM
 3R – 8P – 12FPI
 Height: 210 mm



Standard Built-In Ceiling Fan Coil (Silent)

Capacity: 200-1200 CFM
 3R – 8P – 12FPI
 Height: 230 mm



Fan coil Features

CC: Ceiling Concealed without Plenum or Filter

CD: Ceiling Concealed with Down / Back Return Plenum & Filter

1- Motor
 5- Panel

2- Fan
 6- Drain pan

3- Electrical Box
 7- Collector

4- Coil
 8- Filter

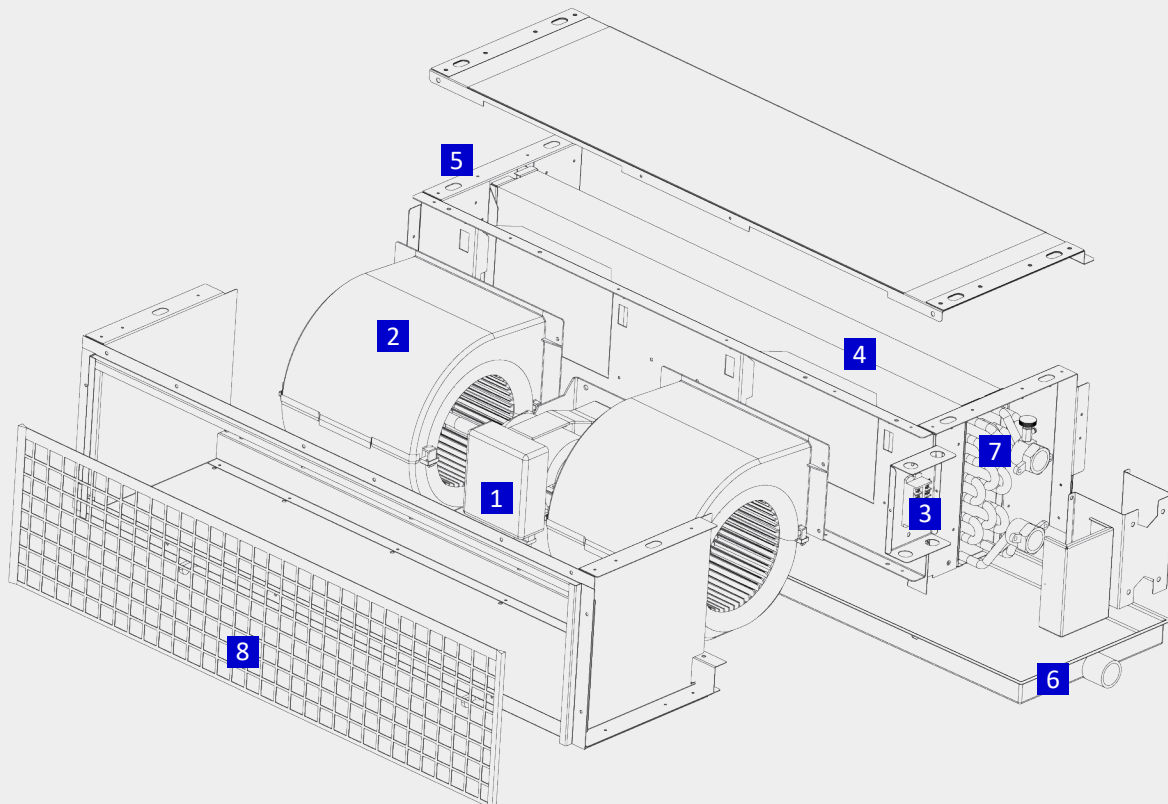

COILS

All cooling and heating coils shall optimize rows and fins per inch to meet the specified capacity. Coils shall have seamless copper tubes and shall be mechanically expanded to provide an efficient, permanent bond between the tube and fin.

Fins shall have high efficiency aluminum surface optimized for heat transfer, air pressure drop and carryover. Heating coils shall be furnished in the reheat position as standard.

Direct expansion cooling coils shall include a fixed orifice metering device. All evaporator coils shall be factory sealed and charged with a minimum 5 PSIG nitrogen or refrigerated dry air.

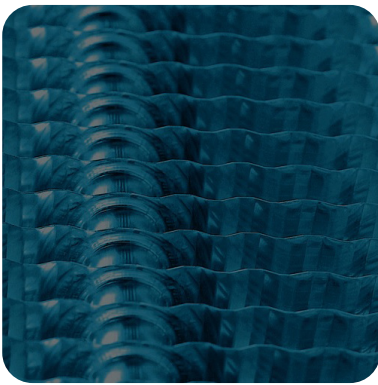
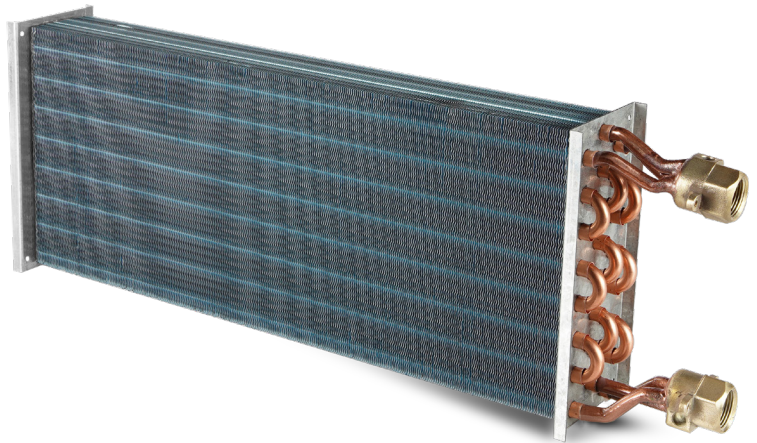

150 Micron Aluminum Fin

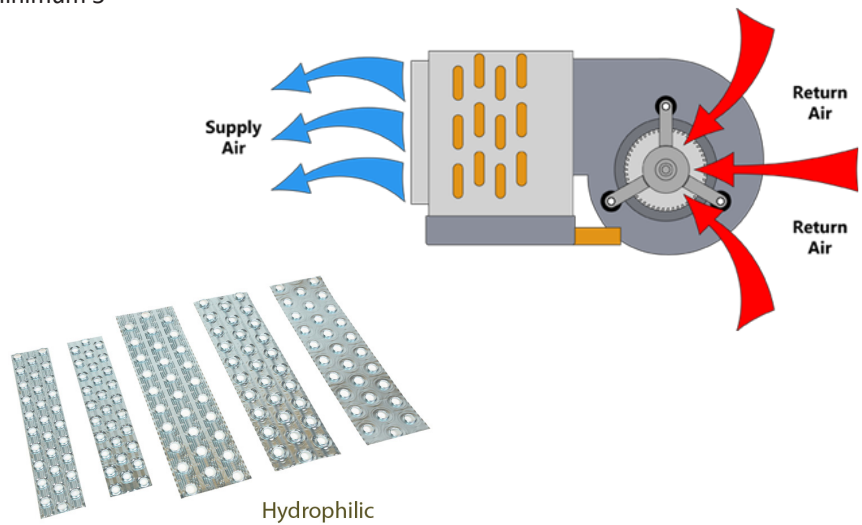

FILTERS

All units shall be made by Aluminum filters. Filters shall be tight fitting to prevent air bypass. Filters shall be easily removable from the return air opening without the need for tools or removal of the front panel. the return air opening.



2 layers Aluminum Filters



فن كویل كانالی Ducted Fan Coil



Ducted Fan Coil

Fan Coil Unit Parameter Data
(10P-3R : Ten pipe Three Rows)



1. Nominal condition,

Cooling: entering air temp 27°C DB/19.5°C WB; entering water temp 7°C, leaving water temp 12°C;

Heating: entering air temp 21°C; entering water temp 60°C, the same water flow as that in cooling;

2. Air flow is tested with standard air condition (20°C DB) and dry coil;

3. Static pressure is measured without filter and air outlet (no plenum).

UNIT			Ducted Fan Coil								
MODEL			MSDC0600	MSDF0800	MSDF1000	MSDF1200	MSDF1400	MSDF1600	MSDF1800	MSDF2000	
COIL	AIR FLOW RATE (CFM)		600	800	1000	1200	1400	1600	1800	2000	
	NOMINAL CAPACITY (BTU/H)	COOLING	TOTAL	25200	29500	33600	37600	44200	50400	54600	57900
			SENSIBLE	16800	20000	23100	26200	29000	33100	36200	38900
	HEATING		50500	63600	76500	88200	104800	121000	132800	144000	
	FACE AREA (SQ.FT)		1.8	1.8	2	2	2.7	3	3	3	
	WATER FLOW RATE (GPM)		5	6	6.5	7.5	9	10	11	11.5	
	PIPING CONNECTION (IN)		1	1	1	1	1	1	1	1	
	FIN ROW/FPI		4/12	4/12	4/12	4/12	4/12	4/12	4/12	4/12	
	WATER PRESSURE DROP (PSI)		2	2.8	3.5	4.5	7.5	9.5	11	12	
MOTOR	POWER SUPPLY (V/Hz)		220-240/50								
	INPUT POWER (HP)		187	187	187	187	187	187+60	187+80	187+80	
	NO OF MOTOR		1	1	1	1	1	2	2	2	
	CLASS		ELECTROGEN (CLASS: A)								
	MAX RPM		1100	1100	1100	1100	1100	1100	1100	1100	
FAN	TYPE		Centrefugal Fan (Metalic Forward Curved)								
	NO OF FAN		2	2	2	2	2	3	3	3	
	AIR FLOW RATE (CFM)		400	600	600	750	750	600	750	750	
	NOISE LEVEL (dB)		48	50	52	52	54	58	60	62	
BODY	DIMENSION (L*W*H)	Cm	100*50*30	100*50*30	105*50*30	105*50*30	130*50*30	140*50*30	140*50*30	140*50*30	
	NET WEIGHT (Kg)		30	33	36	40	45	50	52	54	
	FILTER		Aluminium (Synthic Optional Nylon)								
	DRAIN PAN/ CONNECTION		Galvanized / 1/2								

Ducted Fan Coil Dimension

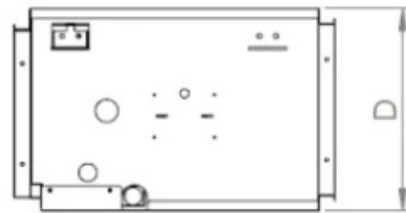
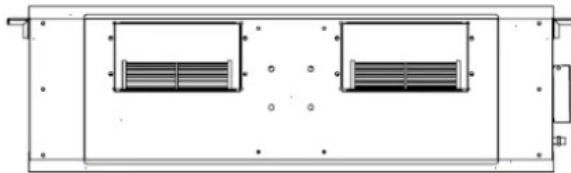
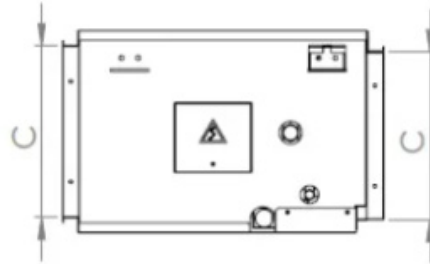
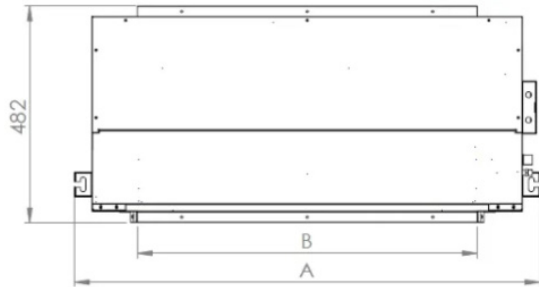

Capacity (CFM)	A (mm)	B (mm)	C (mm)	D (mm)
600	990	710	160	255
800	990	710	160	255
1000	990	710	256	305
1200	1040	760	256	305
1400	1190	910	256	305
1600	1290	1010	256	305
1800	1390	1110	256	305
2000	1390	1110	306	355

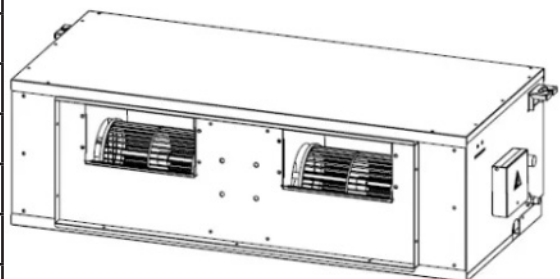

داکت اسپلیت

Duct Split



Indoor Unit Duct Split

MODEL : DSH

CAPACITY : 12000-60000 BTU/HR
 COIL : 3/8- 4 ROW- 14 FPI
 FAN : METALIC CENTRIFUGAL FAN
 MOTOR : ELECTROGEN
 FILTER : 2 LAYER ALUMINIUM
 STATIC PRESSURE : 50 Pa



*Suitable For High Static Pressure In Duct

*Three Standard Speeds With A Low Noise Level

*The Possibility of Removing Fan And Motor From Below

*The Possibility of Using Fresh Air In The Plenum

*Forged Brass Collector With Air Vent And Drain Valve

*EVA Insulator : Drain Pan :5mm ,Body :3mm

UNIT			Duct Split Indoor Unit								
MODEL			DSH12000	DSH18000	DSH24000	DSH30000	DSH36000	DSH42000	DSH48000	DSH60000	
DX COIL	AIR FLOW RATE (CFM)		400	600	800	1000	1200	1400	1600	2000	
	NOMINAL CAPACITY	COOLING TOTAL	TON	1.6	1.8	2.5	2.7	3.2	3.7	4.2	4.7
			BTU/HR	18600	21800	29600	32000	38400	44800	50200	56300
	FACE AREA (SQ.FT)		1.5	1.9	2	2.4	2.7	3	3	3.5	
	FIN ROW/FPI		3/14	4/14	4/14	4/14	4/14	4/14	4/14	4/14	4/14
	LIQUID CONNECTION		3/8	3/8	3/8	3/8	3/8	3/8	1/2	1/2	
	GAS CONNECTION		5/8	5/8	5/8	5/8	5/8	5/8	3/4	3/4	
MOTOR	POWER SUPPLY (V/HZ)		220-240/50								
	INPUT POWER (W)		60	80	187	187	187	187	60+187	80+187	
	NO OF MOTOR		1	1	1	1	1	1	2	2	
	CLASS		ELECTROGEN (CLASS :A)								
	MAX RPM		1100	1100	1100	1100	1100	1100	1100	1100	
FAN	TYPE		Centrifugal Fan (Metalic Forward Curved)								
	NO OF FAN		2	2	2	2	2	2	3	3	
	AIR FLOW RATE (CFM)		300	400	600	600	750	750	600	750	
	NOISE LEVEL (dB)		48	50	52	52	54	58	60	62	
BODY	DIMENSION (L*W*H)	Cm	100*48*25	100*48*25	100*48*30	105*48*30	120*48*30	130*48*30	140*48*30	140*50*35	
	NET WEIGHT (kg)		30	33	36	40	45	50	52	54	
	FILTER		Aluminium (Optional Synthetic Nylon)								
	DRAIN PAN/ CONNECTION		Galvanized / 3/4								

Note :

1- Nominal Conditions

Evaporator Temperature: 7°C

Outdoor Air Temperature : 35°C

Subcooling: 5, Superheat: 10, Altitude: 4000 ft

2- Static Pressure is 50 Pa Measured Without Filter and Air Outlet

Indoor Unit Ducted Split Dimension

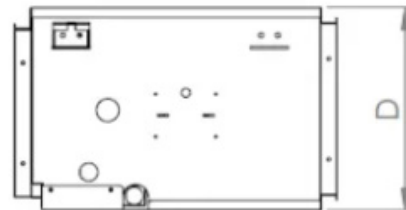
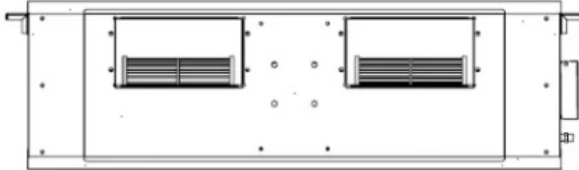
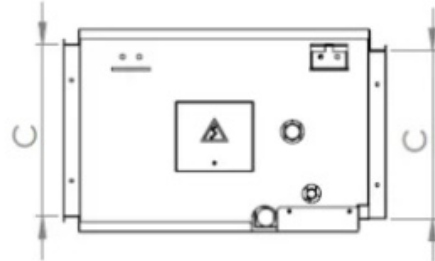
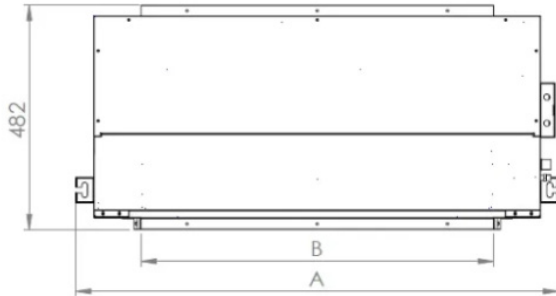

Capacity (BTU/Hr)	A (mm)	B (mm)	C (mm)	D (mm)
12000	990	708	160	253
18000	990	708	160	253
24000	990	708	256	303
30000	1040	758	256	303
36000	1190	908	256	303
42000	1290	1008	256	303
48000	1390	1108	256	303
60000	1390	1108	306	353

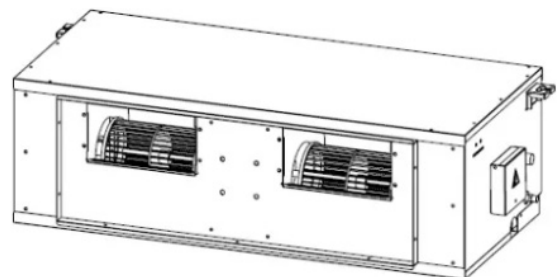

Outdoor Unit Ducted Split Dimension

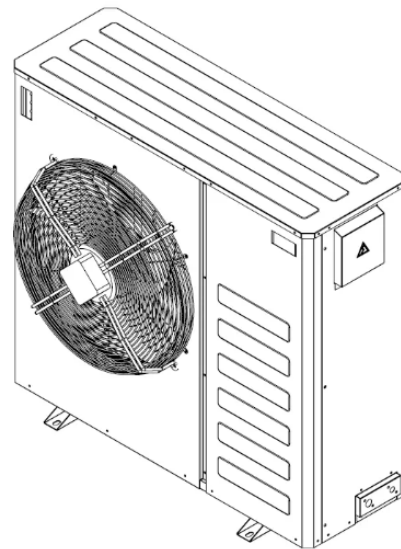
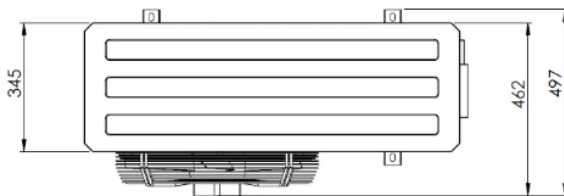
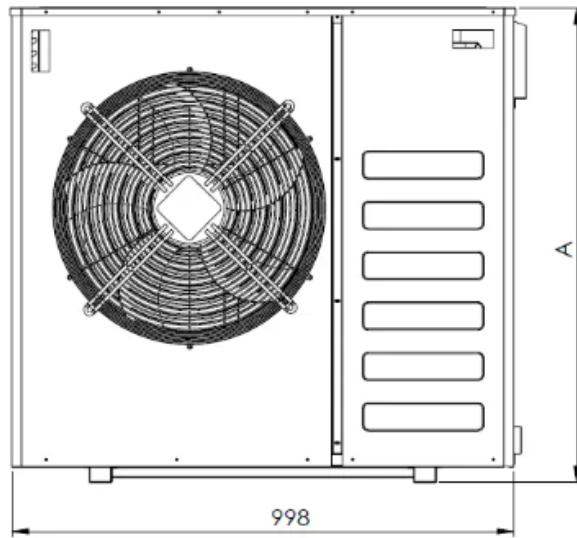
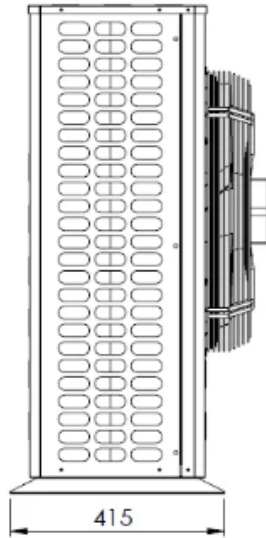

UNIT	A (mm)
600	644
700	744
800	844
900	944
1200	1244

Outdoor Unit



یونیت خارجی

- قدرت برودتی ۲ الی ۵ تن تبرید
- قابلیت سفارش کندانسینگ یونیت در دو نوع Top Discharge & Side Discharge
- مجهز به سیستم آکومولاتور جهت افزایش راندمان دستگاه و کاهش مصرف انرژی
- دارای سیستم کنترل فشار High & Low Pressure
- دارای سیستم ولتاژ به لحاظ وجود نوسانات برق
- طراحی خاص کندانسینگ یونیت به لحاظ سرویس و دسترسی آسان به کلیه تجهیزات
- دارای قاب فلزی با پوشش رنگ پلی استری به منظور حفظ اشعه UV
- تست و شارژ دستگاه در کارخانه پیش از ارسال
- مجهز به شیر برقی جهت یکسان سازی فشار ورودی و خروجی کمپرسور در زمان خاموش بودن کمپرسور (افزایش عمر مفید کمپرسور)
- مجهز به کمپرسور کولپند آمریکا از نوع اسکرال و ساخت کشور تایلند

Indoor Unit



یونیت داخلی

- قدرت هوادهی بالا از ۹۰۰ CFM تا ۲۱۰۰ CFM
- فن سانتریفیوژ با فشار استاتیکی بالا (۱۹۵ Pa)
- راندمان بالا با موتور ۳ الی ۵ دور
- دارای ابعاد مناسب و ارتفاع کم جهت نصب در داخل سقف
- دارای کویل آبگرم فابریک تعبیه شده در داخل دستگاه با حداکثر راندمان
- دارای سیستم عیب یاب هوشمند با قابلیت مانیتور روی نمایشگر ترموستات دیواری
- دارای ترموستات دیواری فابریک
- فیلتر غبارگیری قابل شستشو و جایگزینی با طول عمر بالا
- بدنه هواساز از ورق گالوانیزه با پوشش رنگ پودری مقاوم در برابر خوردگی
- حداقل صدای کارکرد موتور با استفاده از عایق صوتی
- کاربرد آسان در جاگذاری سقفی به جهت ابعاد کوچک با حفظ بیشترین معیارهای نصب افقی و افزایش راندمان
- قابلیت روشن و خاموش شدن متناسب با دمای محیط
- دارای قابلیت Sleep جهت صرفه جویی در مصرف انرژی
- قابلیت برنامه ریزی هفتگی از روی ترموستات

مزایای داکت اسپلیت زانکو

- تولید سرمایش در داخل هواساز
- کویل آبگرم فابریک (تعبیه شده در یونیت داخلی) هماهنگ با سیستم کنترلی دستگاه
- کنترل هر دو حالت گرمایش و سرمایش به وسیله سیستم کنترل دستگاه (ترموستات فابریک)
- قرارگیری هر دو کویل سرمایشی و گرمایشی در مکش دستگاه جهت افزایش راندمان و کارایی
- مجهز به ترموستات دیواری تولید شده در کمپانی سازنده هواساز و کندانسینگ یونیت
- هوادهی بالا در تمام ظرفیت‌ها (ظرفیت ۲ تن برابر با ۹۰۰ cfm و ظرفیت ۳ تن برابر با ۱۳۰۰ cfm)
- کلاس انرژی A و B مجهز به شیر انبساط حرارتی (TXV) جهت تنظیم دقیق و هوشمند سوپرهیت
- (constant superheat) که علاوه بر افزایش کارایی و راندمان دستگاه موجب افزایش عمر مفید کمپرسور نیز می‌گردد. (آپشن سفارشی)

مزایا و امکانات ترموستات دیجیتال

- امکان نصب بر روی انواع سیستم‌های تهویه مطبوع اعم از فن کوئل، هواساز و داکت اسپلیت (با هیت پمپ و بدون هیت پمپ)
- قابلیت اتصال به صورت wifi و کنترل از هر نقطه دنیا به وسیله اپلیکیشن اختصاصی برای android
- مجهز به تقویم و برنامه هفتگی جهت برنامه‌ریزی میزان دما در روزهای هفته (ساعت به ساعت)
- دارای سه سرعت فن به صورت دستی و اتوماتیک (تغییر سرعت فن متناسب با دمای محیط)
- کنترل تغییر وضعیت (مد) در سه حالت (سرمایش / گرمایش / گردش هوا)
- تشخیص، نمایش و کنترل دمای محیط
- ولتاژ کاری از ۸۰ تا ۲۲۰ ولت برق شهر
- طراحی زیبا مطابق با استانداردهای اروپا
- مجهز به تایمر خواب (sleep)
- صرفه‌جویی در مصرف انرژی
- نصب ساده و آسان
- ابعاد ۸۷ * ۸۷ میلی‌متر (ابعاد کلید برق)



Zanco

تامین قطعات یدکی و لوازم جانبی

زانکو با ایجاد انبارهای اصلی و فرعی قطعات یدکی در سراسر کشور، کلیه قطعات یدکی اورجینال و فابریک دستگاه را در اختیار شبکه نمایندگان مجاز قرار داده تا در کوتاه‌ترین زمان ممکن به دست مصرف‌کنندگان برسد. همچنین تامین قطعات یدکی مورد نیاز مشتریان پس از اتمام دوره گارانتی از جمله موارد تضمین شده شرکت می‌باشد.



www.jtdpac.com

خدمات پس از فروش نوین

واحد خدمات پس از فروش به عنوان یکی از ارکان اصلی زانکو با سرلوحه قراردادن کیفیت، سرعت و دقت در خدمات، همواره در اندیشه ارتقاء سطح رضایتمندی مشتریان می‌باشد.

به همین منظور کلیه فعالیت‌های سرویس و خدمات را با تکیه بر کادر مجرب، دانش نرم‌افزاری بروز، فناوری‌های نوین و شبکه گسترده نمایندگان مجاز در سراسر کشور ارائه می‌دهد. مشاوره و پیشنهاد فنی پیش از انتخاب محصول و طراحی نقشه‌های مهندسی اجرای زیرساخت، از جمله خدمات درحین فروش بشمار می‌آید.



جهان تاسیسات

جهان تاسیسات دیاکو پارس

شرکت جهان تاسیسات دیاکو پارس
نماینده انحصاری سیستم‌های تهویه مطبوع و تبرید زانکو در ایران

www.zanco.co

www.jtdpac.com



Zanco

جهان
تاسیسات

محصولات زانکو با ضمانت جهان تاسیسات دیاکو پارس



www.zanco.co

دفتر مرکزی (شمال): آمل، کیلومتر ۵ جاده هراز، سیتی سنتر اکسین، طبقه دوم، پلاک ۲۰۳

کارخانه: پردیس، جاده آبعلی، بلوار خرمدشت، خیابان هشتم شرقی، پلاک ۷۵

تلفن: ۰۱۱ - ۴۱ ۲۱

📍 Address: No.203, Oxin City Center, 5th kilometer of Haraz Rd, Mazandaran - Iran

📍 Address (Factory): No.75, East 8th St., Khoramdasht Blvd, Abali Road, Pardis - Iran

📞 **Tell: 011 41 21**

✉ Telegram: 09120586090

📷 Instagram: @zanco.co

🌐 Website: www.zanco.co

✉ E-mail: info@zanco.co